

# FRRU004-AIM

## Analog Input Module

### Features

- Monitors the analog input of 4 to 20 mA
- One simple LED for status indication
- SLC Class B, Class A, and Class X
- Electrical address setting
- Downsized unit
- Easy installation



### Description

The FRRU004-AIM module is used to monitor industry-standard, linear-scale, 4–20 mA protocol sensors. The FRRU004-AIM converts the sensor output to communication protocol that can be interpreted by the FACP for monitoring and display. There are numerous sensors available in the marketplace that communicate using a 4–20 mA output, including gas sensors, temperature sensors, air speed sensors, and more. The FRRU004-AIM employs one red LED to indicate the status. The normal condition is indicated by flashing LED. The input condition is indicated by constant illumination. The trouble condition is indicated by extinction.

### Ordering Information

Model no. FRRU004-AIM

### Specifications

No.	Item	Specification
1	Rated voltage range of SLC input power (S+,S-)	22.0 to 24.0 V
2	Maximum SLC 24 VDC standby current (S+,S-)	250 $\mu$ A
3	Maximum SLC 24 VDC alarm current (S+,S-)	250 $\mu$ A
4	Operating voltage of external power supply line (24+,24-)	24 VDC
5	Rating for connected V+,V-	0.5 A
6	Sensor signal loop current	4-20mA
7	Consumption current of the board at standby	1mA
8	Consumption current of the board at alarm	3mA
9	Maximum number of sensor per module	1unit
10	Operating temperature range	0 to 49°C (32 to 120 °F)
11	Operating humidity range	0 to 93% (non-condensing)
12	Address per module	1 address
13	Dimensions	4.17"(106mm) (H) × 4.17"(106mm) (W) × 1.14"(29mm) (D)

### Setting the Address

Each addressable module, smoke detector, heat detector and combination detector must have the address set before connecting the device to the Signaling Line Circuit (SLC) loop. The address is set using the hand held device programmer.

## Installation

Figure 1: Installation into the compatible electrical box

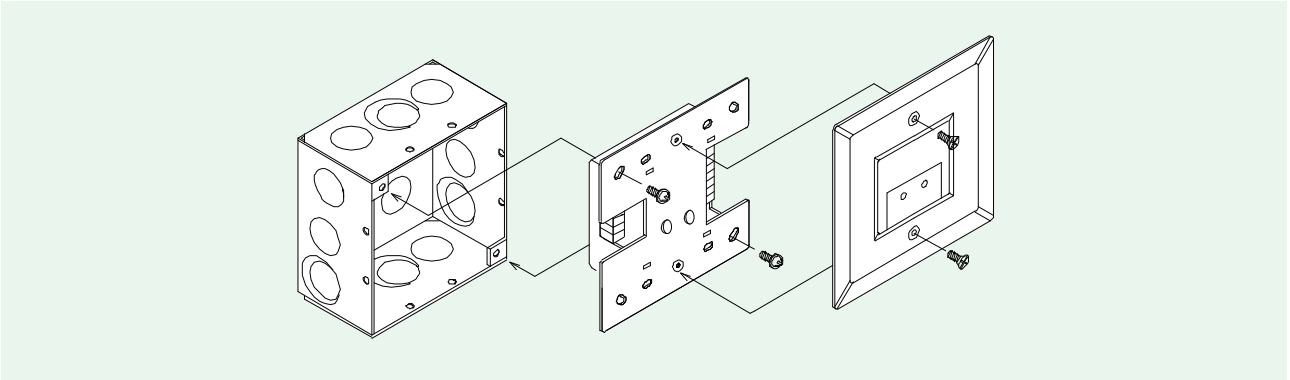

## Wiring Diagram

Figure 2: Wiring diagram of FRRU004-AIM

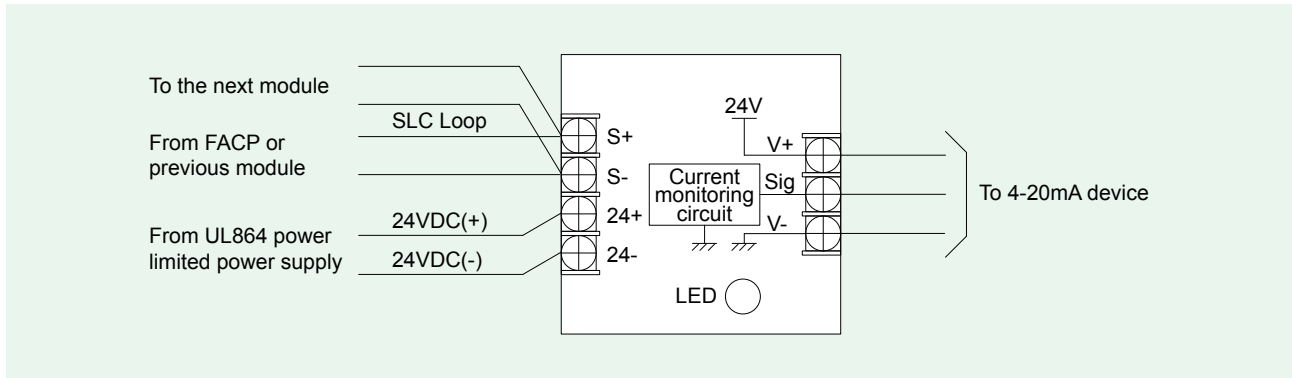

### Notice

- These instructions do not purport to cover all the details or variations in the equipment described, nor provide for every possible contingency to be met in connection with installation, operation and maintenance.
- Specifications are subject to change without notice. Contact Nohmi before relying on above specifications.
- Actual performance is based on proper application of the product by a qualified professional.
- Should further information be desired or should particular problems arise, which are not covered sufficiently for the purchaser's purpose, the matter should be referred to Nohmi or a distributor in your region.

**NOHMI**  
NOHMI BOSAI LTD.

- Head Office: 4-7-3 Kudan-Minami, Chiyoda-ku, Tokyo 102-8277, Japan
  - Phone: (81)3-3265-0231
  - F A X: (81)3-3265-5348
- URL <https://www.nohmi.co.jp/english/>

Contact